



**AFFETTI**

Pumps for corrosive liquids



Pompe centrifughe  
verticali con  
supporto  
e giunto  
elastico

Centrifugal sump  
pumps with  
support  
and elastic  
coupling

series  
**CGV**  
**CGV-N**

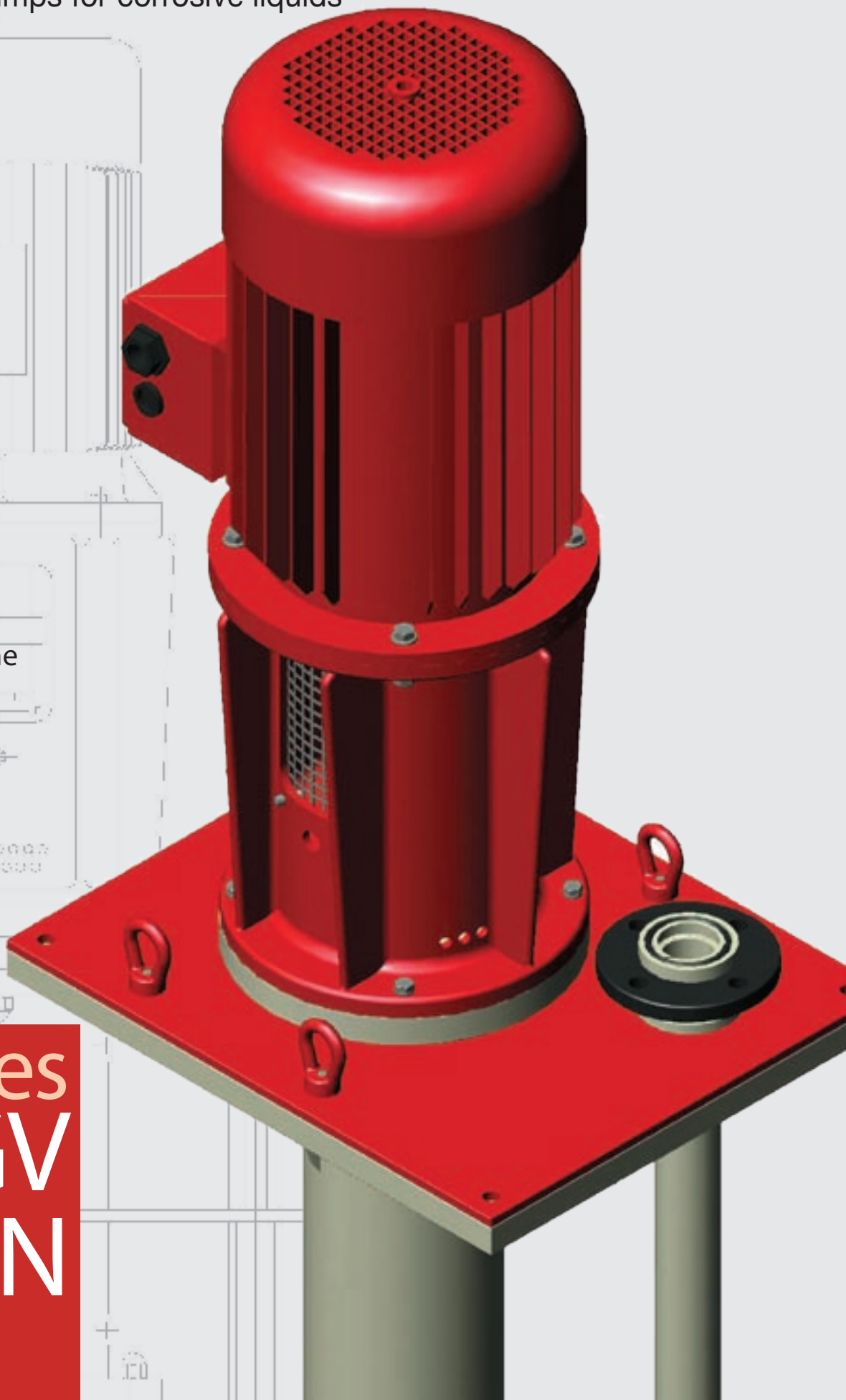

# CGV-N

**1** Tubo di mandata in termoplastico .

**2** Corpo-pompa in PP, PVDF, PEHD ricavato interamente da lavorazione meccanica. Per le macchine 25-125,32-125,40-130,40-160,50-160,il pezzoviene stampato ad iniezione solo in PP e PVDF.

**3** Girante centrifuga in PP, PVDF, PE-UHMW , (per le macchine 25-100, 25-125, 32-125, 40-130, 40-160, 50-160, il pezzo è realizzato solo in PP e PVDF) ; versione semi-aperta per liquidi carichi e chiusa per il pompaggio di soluzioni con temperature elevate. Autobilanciamento assiale garantito da contropaletture posteriori, inserto centrale metallico protetto .

**4** Bussola di guida statica in PTFE CG (su richiesta in SiC )

**5** Motore elettrico asincrono trifase secondo la normativa IEC (a richiesta NEMA).

**6** Colonna costruita interamente in termoplastico

**7** Piastra di elevato spessore in PP rinforzata con una lamiera d'acciaio.

**8** Bussola di guida rotante in Al<sub>2</sub>O<sub>3</sub> (su richiesta in SiC) .

**9** Albero bilanciato in acciaio al carbonio 39NiCrMo<sub>3</sub>, strutturato per sopportare agevolmente forze torsionali e radiali. Ricavato completamente da barra piena tramite lavorazione meccanica è rivestito completamente in termoplastico

**10** Lanterna in ghisa contiene il supporto dei cuscinetti ed il giunto elastico e distanzia il motore dal resto della pompa .

**11** Supporto in acciaio alloggiando due cuscinetti a sfere che guidano l'albero

**12** Giunto elastico montato per assorbire eventuali disallineamenti dell'asse, inoltre consente lo smontaggio del motore senza dover rimuovere la pompa

## Legenda

PP	polipropilene
PVDF	floruro di polivinilidene
PEHD	polietilene alto peso molecolare
PE-UHMW	polietilene ultra alto peso molecolare
EPDM	etilenpropilene
FPM	fluoroelastomero
FFKM	perfluoroelastomero
PTFE-CG	politetrafluoruro etilene caricato carbo-grafite
Al <sub>2</sub> O <sub>3</sub>	allumina
SiC	carburo di silicio

## Legend

PP	polypropylene
PVDF	polyvinylidene fluoride
PEHD	high molecular weight polyethylene
PE-UHMW	extra-high molecular weight polyethylene
EPDM	ethyl propylene diene monomer
FPM	fluoroelastomer
FFKM	perfluoroelastomer
PTFE-CG	carbon-graphite reinforced polytetrafluoroethylene
Al <sub>2</sub> O <sub>3</sub>	alumina
SiC	silicon carbide

**1** Thermoplastic discharge pipe.

**2** Casing made of extra-thick PP, PVDF or PEHD, manufactured using mechanical machining processes. For pump models 25-125, 32-125, 40-130, 40-160 and 50-160, the part is injection moulded and is only available in PP or PVDF.

**3** Centrifugal impeller in PP, PVDF or PE-UHMW (the part is only available in PP or PVDF for pump models 25-100, 25-125, 32-125, 40-130, 40-160 and 50-160); semi-open version for particle-loaded fluids or closed for pumping solutions at high temperatures. Axial self-balancing guaranteed by rear counterblades; protected central metal insert.

**4** Static guide bushing in PTFE CG (SiC available on request)

**5** Three-phase asynchronous electric motor, in compliance with IEC (NEMA available on request).

**6** Column manufactured entirely from thermoplastic material.

**7** Extra-thick PP plate reinforced with a sheet of steel.

**8** Revolving guide bushing in Al<sub>2</sub>O<sub>3</sub> (SiC available on request).

**9** Balanced shaft made of 39NiCrMo<sub>3</sub> carbon steel, structured to easily support torsional and radial forces. Made exclusively from solid bar stock using mechanical machining processes and fully coated in thermoplastic material.

**10** Intermediate adaptor in cast iron contains the support for the bearings and the elastic coupling and distances the motor from the rest of the pump.

**11** Steel support houses two ball bearings that guide the shaft.

**12** Elastic coupling fitted to absorb any axial misalignment and allow the motor to be disassembled without having to remove the pump

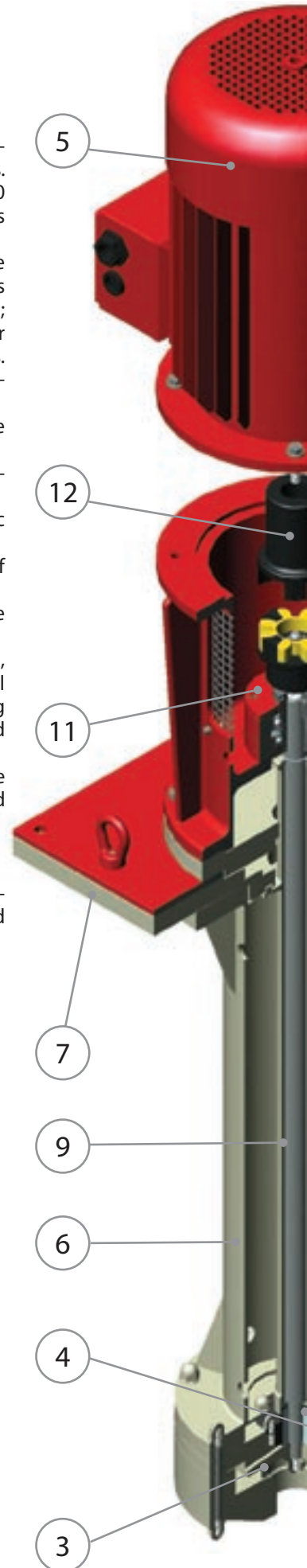

# CGV CGV-N

## Caratteristiche generali

- Adatta al pompaggio di liquidi corrosivi in
- Costruzione solida
- Albero collegato al motore tramite giunto elastico e guidato da bussole in Al<sub>2</sub>O<sub>3</sub> PTFE-CG
- Motore e piastra distanziati da una lanterna
- Facile manutenzione
- Lunghezza della colonna da 500 a 3000 mm
- Verniciatura motore e parti metalliche primer epossidico 50/80 µm più strato poliuretano 70/80 µm rosso RAL 3001

## Materiali

- Parti a contatto con il liquido pompato

in PP – PVDF – PEHD – PE-UHMW

- O-rings e guarnizioni in EPDM – FPM – FFKM
- Albero in acciaio 39NiCrMo3 rivestito in termoplastico

## Temperature d'esercizio

- PP 0° C + 80 ° C
- PVDF -10° C +100° C
- PEHD -5° C + 70° C

## Accessori

- Attacco flangiato in mandata
- Tettuccio parapiovra motore
- Filtro montato in aspirazione
- Tubo di prolunga montato in aspirazione
- Raccordo di lavaggio bussole di guida

## General characteristics

- Suitable for pumping corrosive fluids
- Solid construction
- Shaft attached to the motor with an elastic coupling and guided by Al<sub>2</sub>O<sub>3</sub> - PTFE-CG bushings
- Motor and plate distanced by an intermediate adaptor
- Easy to maintain
- Column length from 500 to 3000 mm
- Painting of motor and metallic parts: 50/80 µm epoxy primer plus 70/80 µm coat of polyurethane RAL 3001 red

## Materials

- Parts in contact with the fluid pumped made of PP – PVDF – PEHD – PE-UHMW
- O-rings and seals in EPDM – FPM – FFKM
- Shaft in thermoplastic-coated 39NiCrMo3 steel

## Working temperatures

- PP 0° C + 80° C
- PVDF -10° C +100° C
- PEHD -5° C + 70° C

## Accessories

- Flanged connection on discharge line
- Motor rain guard
- Filter on suction line
- Extension pipe on suction line
- Guide bushing washing fitting

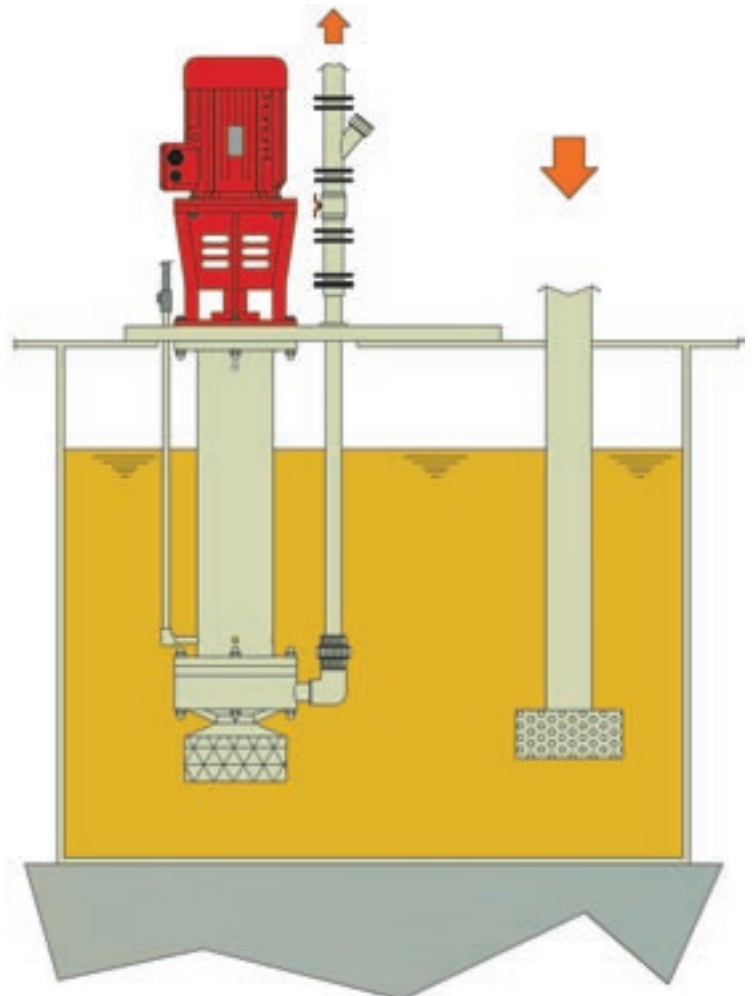

# CGV-N

## Dimensioni d'ingombro Overall dimensions

La bocca di mandata può montare di serie flange ISO (a richiesta ANSI o JIS). I motori installati sono asincroni trifase e selezionati in base alle prestazioni richieste e rispondono alle normative IEC (a richiesta NEMA). Le frequenze disponibili sono 50 e 60 Hz

The discharge outlet is supplied with ISO flange connections (ANSI or JIS connections are available on request). The pumps are fitted with three-phase asynchronous motors, manufactured in accordance with the IEC standard (NEMA available on request), and selected according to the performance required. 50 and 60 Hz frequencies are available

Type	Motor min/max	A	B	H	M	N	O	dnA	dnM	ØA	ØM	a	b	c	K	Ør
32-125	80	480	400		345	26	210	50	32	2"	1 1/4"	100	140	18	4	1/2"
	400															
32-200	90	710	540		345	36	250	50	32	2"		100	140	18	4	1/2"
	500															
40-130	80	530	450		345	36	210	50	40	2"	1/2"	110	150	18	4	1/2"
	400															
40-160	80	610	500		345	36	210	65	40	2 1/2"	1/2"	110	150	18	4	1/2"
	500															
40-200	80	710	540		345	36	210	65	40	2 1/2"		110	150	18	4	1/2"
	500															
50-160	80	610	500	500-750-1000-1250-1500-1750-2000-2250-2500-2750-3000 (±5)	345	36	210	65	50	2 1/2"	2"	125	165	18	4	1/2"
	500															
50-200	80	715	550		345	50	250	80	50	3"		125	165	18	4	1/2"
	620															
50-250	90	720	565		345	50	300	80	50	3"		125	165	18	4	1/2"
	690															
50-315	100	870	550		345	50	300	80	50	3"		125	165	18	4	1/2"
	500															
65-125	90	670	500		345	36	250	100	65	4"		145	185	18	4	1/2"
	500															
65-160	90	670	500		345	36	250	100	65	4"		145	185	18	4	1/2"
	500															
65-200	90	710	540		345	50	250	100	65	4"		145	185	18	4	1/2"
	570															
65-250	90	750	570		345	50	250	100	65	4"		145	185	18	4	1/2"
	570															
80-200	90	710	534		345	50	250	125	80	5"		160	200	18	8	1/2"
	690															
80-250	112	760	570		345	50	330	125	80	5"		160	200	18	8	1/2"
	570															
80-315	112	950	550		345	50	330	125	80	5"		160	200	18	8	1/2"
	620															
100-250	100	864	570		345	50	300	125	100	5"		180	220	18	8	1/2"
	570															
150-250	132	930	600		345	55	400	200	150	8"		240	290	22	8	1/2"
	690															
150-315	160	1145	620		345	55	500	200	150	8"		240	290	22	8	1/2"
	830															

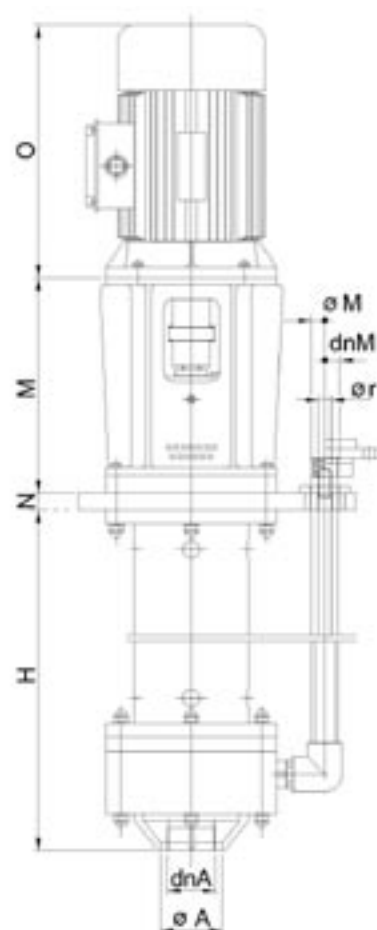
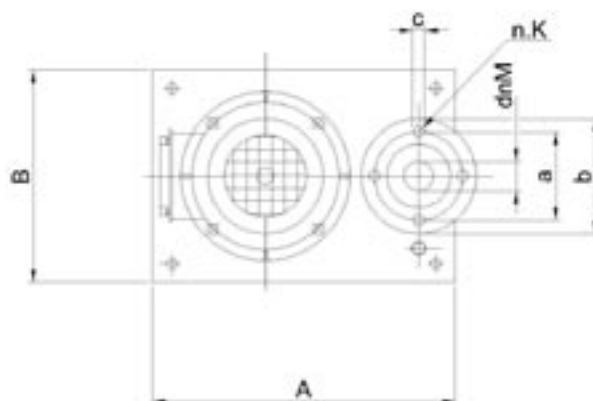
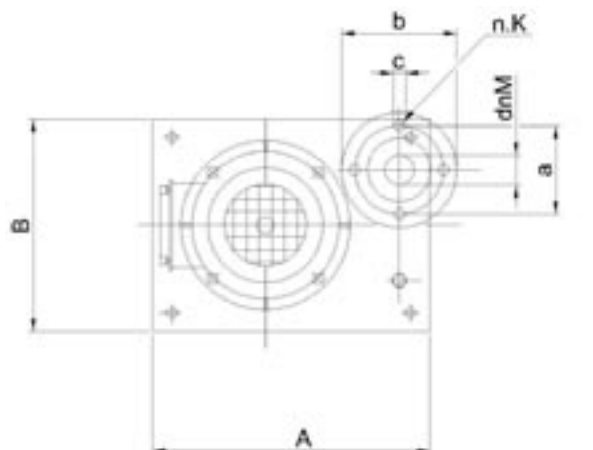

**1** Tubo di mandata in termoplastico .

**2** Corpo-pompa in PP, PVDF, PEHD ricavato interamente da lavorazione meccanica. Per le macchine 25-125, 32-125, 40-130, 40-160, 50-160, il pezzo viene stampato ad iniezione solo in PP e PVDF.

**3** Girante centrifuga in PP, PVDF, PE-UHMW, (per le macchine 25-100, 25-125, 32-125, 40-130, 40-160, 50-160, il pezzo è realizzato solo in PP e PVDF); versione semi-aperta per liquidi carichi e chiusa per il pompaggio di soluzioni con temperature elevate. Autobilanciamento assiale garantito da contropaletture posteriori, inserto centrale metallico protetto.

**4** Bussola di guida statica in PTFE CG (su richiesta in SiC)

**5** Motore elettrico asincrono trifase secondo la normativa IEC (a richiesta NEMA).

**6** Colonna costruita interamente in termoplastico

**7** Piastra di elevato spessore in PP.

**8** Bussola di guida rotante in Al<sub>2</sub>O<sub>3</sub> (su richiesta in SiC) .

**9** Albero bilanciato in acciaio al carbonio 39NiCrMo<sub>3</sub>, strutturato per sopportare agevolmente forze torsionali e radiali. Ricavato completamente da barra piena tramite lavorazione meccanica è rivestito completamente in termoplastico

**10** Lanterna in alluminio contiene il supporto dei cuscinetti ed il giunto elastico e distanzia il motore dal resto della pompa .

**11** Supporto in alluminio alloggiavano due cuscinetti a sfere che guidano l'albero

**12** Giunto elastico montato per assorbire eventuali disallineamenti dell'asse, inoltre consente lo smontaggio del motore senza dover rimuovere la pompa.

**1** Thermoplastic discharge pipe.

**2** Pump-body made of extra-thick PP, PVDF or PEHD, manufactured using mechanical machining processes. For pump models 25-125, 32-125, 40-130, 40-160 and 50-160, the part is injection moulded and is only available in PP or PVDF.

**3** Centrifugal impeller in PP, PVDF or PE-UHMW (the part is only available in PP or PVDF for pump models 25-100, 25-125, 32-125, 40-130, 40-160 and 50-160); semi-open version for particle-loaded fluids or closed for pumping solutions at high temperatures. Axial self-balancing guaranteed by rear counterblades; protected central metal insert.

**4** Static guide bushing in PTFE CG (SiC available on request)

**5** Three-phase asynchronous electric motor, in compliance with IEC (NEMA available on request).

**6** Column manufactured entirely from thermoplastic material.

**7** Plate in extra-thick PP.

**8** Revolving guide bushing in Al<sub>2</sub>O<sub>3</sub> (SiC available on request).

**9** Balanced shaft made of 39NiCrMo<sub>3</sub> carbon steel, structured to easily support torsional and radial forces. Made exclusively from solid bar stock using mechanical machining processes and fully coated in thermoplastic material.

**10** Intermediate adaptor in aluminium contains the support for the bearings and the elastic coupling and distances the motor from the rest of the pump.

**11** Aluminium support houses two ball bearings that guide the shaft.

**12** Elastic coupling fitted to absorb any axial misalignment and allow the motor to be disassembled without having to remove the pump.

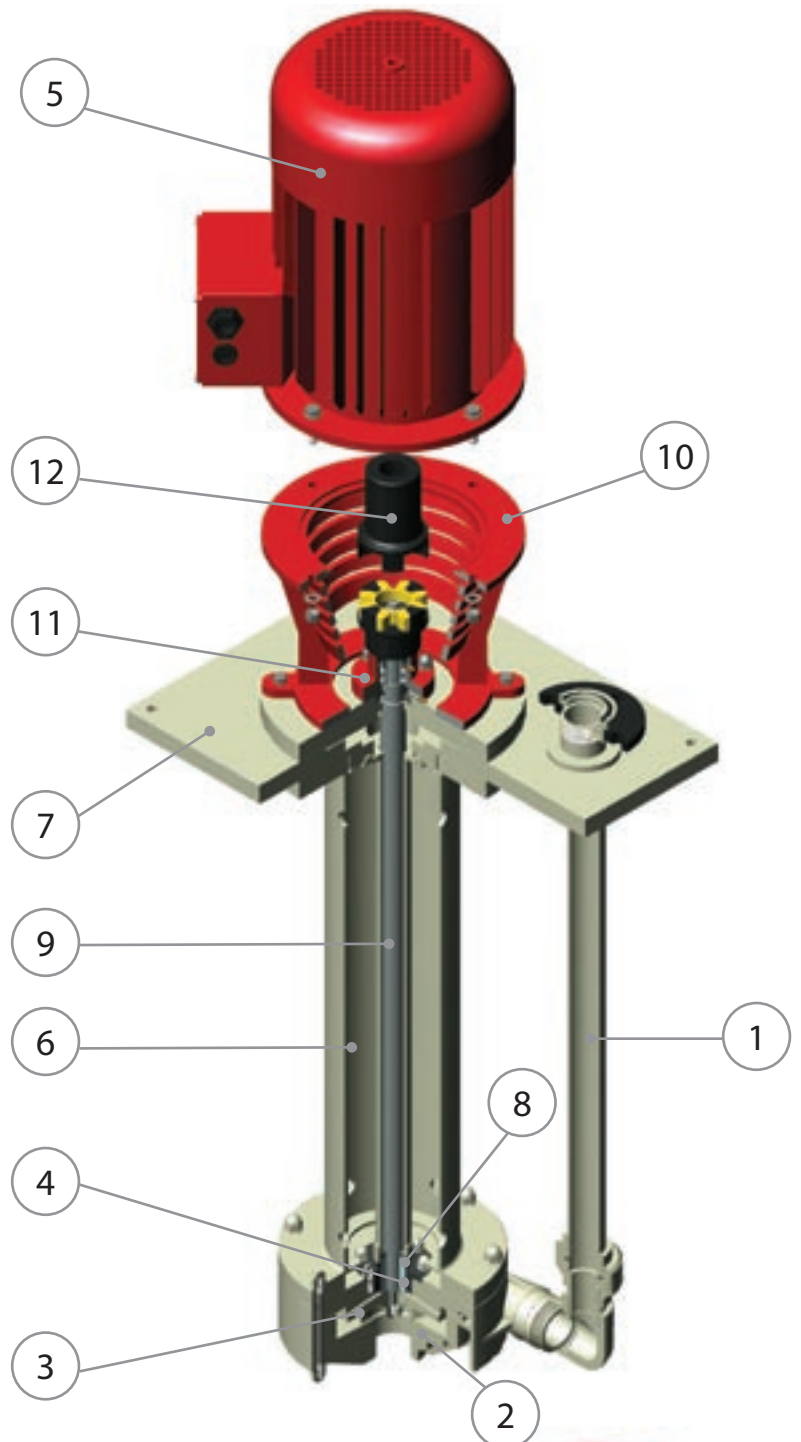

## Legend

PP	polypropylene
PVDF	polyvinylidene fluoride
PEHD	high molecular weight polyethylene
PE-UHMW	extra-high molecular weight polyethylene
EPDM	ethyl propylene diene monomer
FPM	fluoroelastomer
FFKM	perfluoroelastomer
PTFE-CG	carbon-graphite reinforced
polytetrafluoroethylene	
Al <sub>2</sub> O <sub>3</sub>	alumina
SiC	silicon carbide

## Legenda

PP	polipropilene
PVDF	floruro di polivinilidene
PEHD	polietilene alto peso molecolare
PE-UHMW	polietilene ultra alto peso molecolare
EPDM	etilenpropilene
FPM	fluoroelastomero
FFKM	perfluoroelastomero
PTFE-CG	politetrafluoruro etilene caricato
	carbo-grafite
Al <sub>2</sub> O <sub>3</sub>	allumina
SiC	carburo di silicio



## Dimensioni d'ingombro Overall dimensions

La bocca di mandata può montare di serie flange ISO (a richiesta ANSI o JIS). I motori installati sono asincroni trifase e selezionati in base alle prestazioni richieste e rispondono alle normative IEC (a richiesta NEMA). Le frequenze disponibili sono 50 e 60 Hz

The discharge outlet is supplied with ISO flange connections (ANSI or JIS connections are available on request). The pumps are fitted with three-phase asynchronous motors, manufactured in accordance with the IEC standard (NEMA available on request), and selected according to the performance required. 50 and 60 Hz frequencies are available.

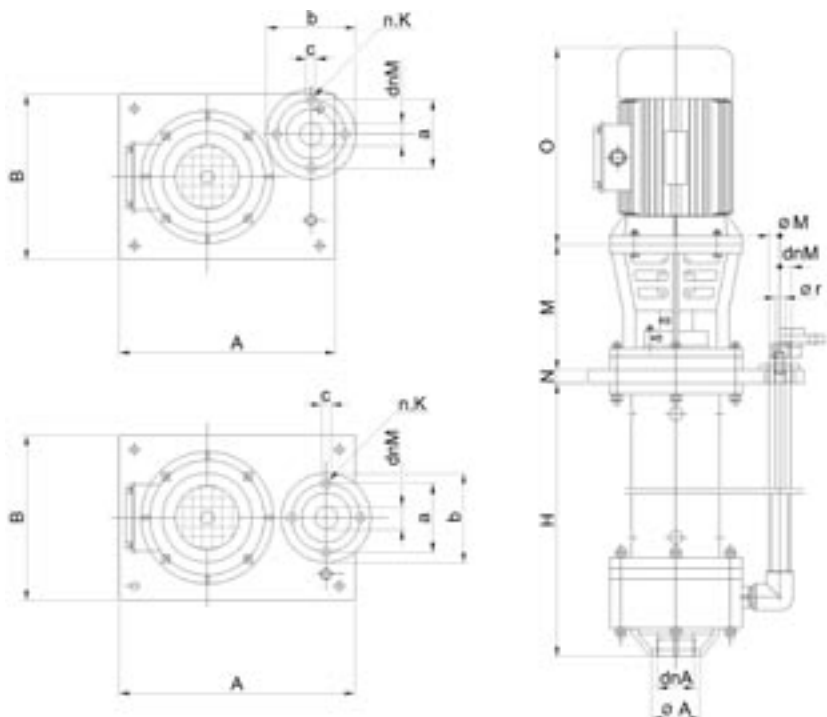

Type	Motor min/max	A	B	H	M	N	O	dnA	dnM	ØA	ØM	a	b	c	K	Ør
25-100	71	410	350	500-750-1000-1250-1500-1750-2000-2250-2500-3000 (±5)	170	20	176	40	25	1½"	1"	85	100	14	4	½"
	90				200		226									
25-125	80	410	350		200	20	209	40	25	1½"	1"	85	100	14	4	½"
	100				226		272									
32-125	80	480	400		200	20	209	50	32	2"	1¼"	100	140	18	4	½"
	112				226		299									
32-200	90	710	540		200	30	226	50	32	2"		100	140	18	4	½"
	160				288		455									
40-130	80	530	450		200	30	209	50	40	2"	1½"	110	150	18	4	½"
	132				268		370									
40-160	80	610	500		200	30	209	65	40	2"	1"	110	150	18	4	½"
	160				268		390									
40-200	80	710	540	200	30	209	65	40	2½"		110	150	18	4	½"	
	160			288		390										
50-160	80	610	500	200	30	209	65	50	2½"	1½"	125	165	18	4	½"	
	160			288		455										
50-200	90	710	540	200	40	248	80	50	3"		125	165	18	4	½"	
	200			288		500										
65-125	90	670	500	200	30	248	100	65	4"		145	185	18	4	½"	
	160			288		455										
65-160	90	750	570	200	30	248	100	65	4"		145	185	18	4	½"	
	160			288		455										

## Curve caratteristiche

Tutte le macchine prodotte sono sottoposte, una per una, a tests idromeccanici con acqua a temperatura di 18°C e sono garantite fino a PN10.

## Characteristic curves

All of the pumps manufactured are subjected to hydro-mechanical tests, one by one, with water at a temperature of 18°C and are guaranteed up to PN10.

**2900 RPM/50 Hz**

US gpm

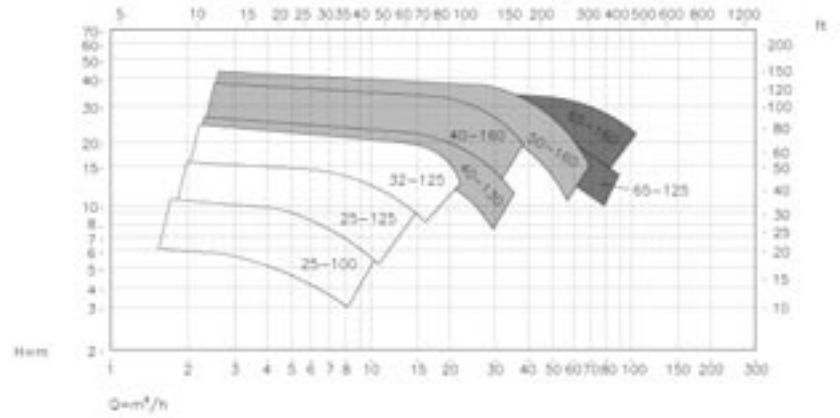

**1450 RPM/50 Hz**

US gpm

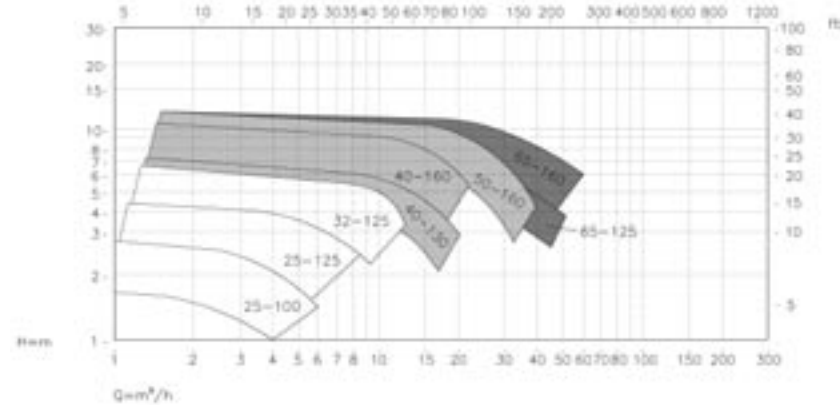

**3450 RPM/60 Hz**

US gpm

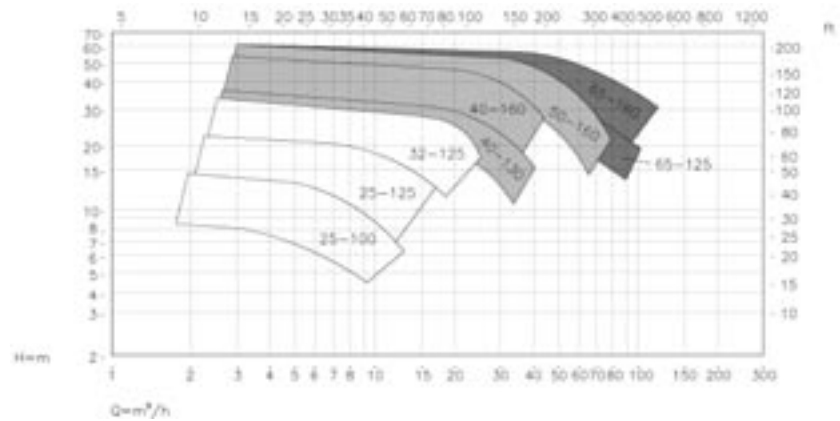

**1750 RPM/60 Hz**

US gpm

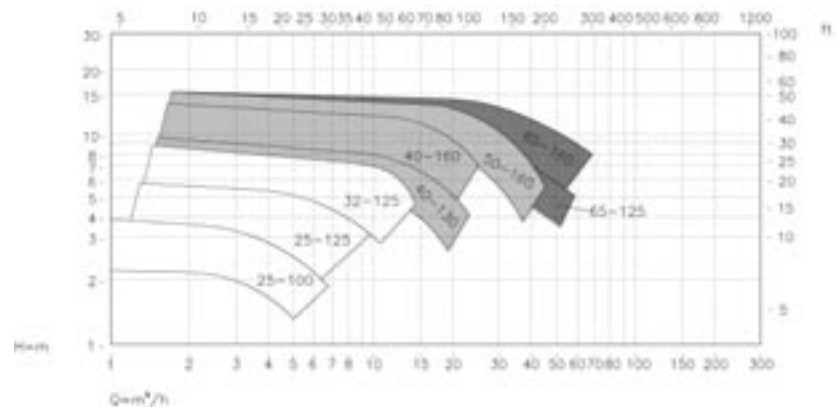

I dati di questo catalogo sono indicativi ma non impegnativi e possono subire delle variazioni senza alcun preavviso.

The data contained in this catalogue is indicative but not binding and may be subject to change without any prior warning.

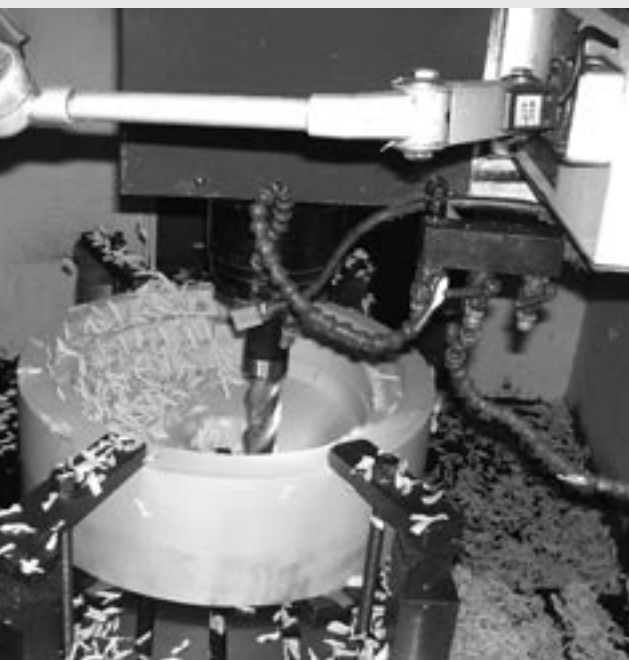

**AFFETTI**  
Pumps for corrosive liquids

**AFFETTI GIUSEPPE & C. s.n.c**

Via P. Maroncelli, 4  
21053 CASTELLANZA (VA) - ITALY

tel. +39 331 503358 +39 331 505595

fax. +39 331 483007

e-mail for Italy: [vendite@affetti](mailto:vendite@affetti)

e-mail for others countries : [export@affetti.com](mailto:export@affetti.com)

web site: [www.affetti.com](http://www.affetti.com)

Distributore autorizzato - Authorized distributor